

100% STABILIZATION. GUARANTEED.

DUSTMASTER



Reuse, Recycle
or Dispose of Fine,
Dusty or Powdery Hazardous and
Non-Hazardous Materials

WE HAVE NOT ENCOUNTERED A DUST WE CANNOT SUCCESSFULLY PROCESS.

When

you have a difficult waste or recycle problem

involving dusts, powders or fine materials, call the experts at DustMASTER. We've successfully handled numerous types of hazardous and non-hazardous dusts at industries around the world.

We can assess your needs—then design, build, and install a system to fit those needs. A DustMASTER system will allow you to economically recover valuable product; will allow you to reuse formerly wasted materials; or will allow you to inexpensively dispose of your dust while complying with environmental requirements or restrictions.

The systems we supply are universally acknowledged to simplify processing, handling, storage and transportation. Our systems achieve 100% stabilization, with consistent results. And we guarantee to turn any problem material into a uniform non-dusting product.

DustMASTER Enviro Systems can be your single source for providing a total solution on a turnkey basis. As a start, please ask us about our user lists and ask to see our video.

SINGLE SOURCE

Single Source Fugitive Dusts and

Inward and Outward Facing Mixing Paddles



constantly force materials back and forth, creating a superior braiding action without dead spots. Paddles

have unique concave faces, forcing materials upwards to create a rolling-mixing action within the braid.

Inner and Outer Wall Scraper Blades prevent peripheral "dead zones," are cast Ni-Hard steel for wear resistance and segmented for inexpensive replacement.

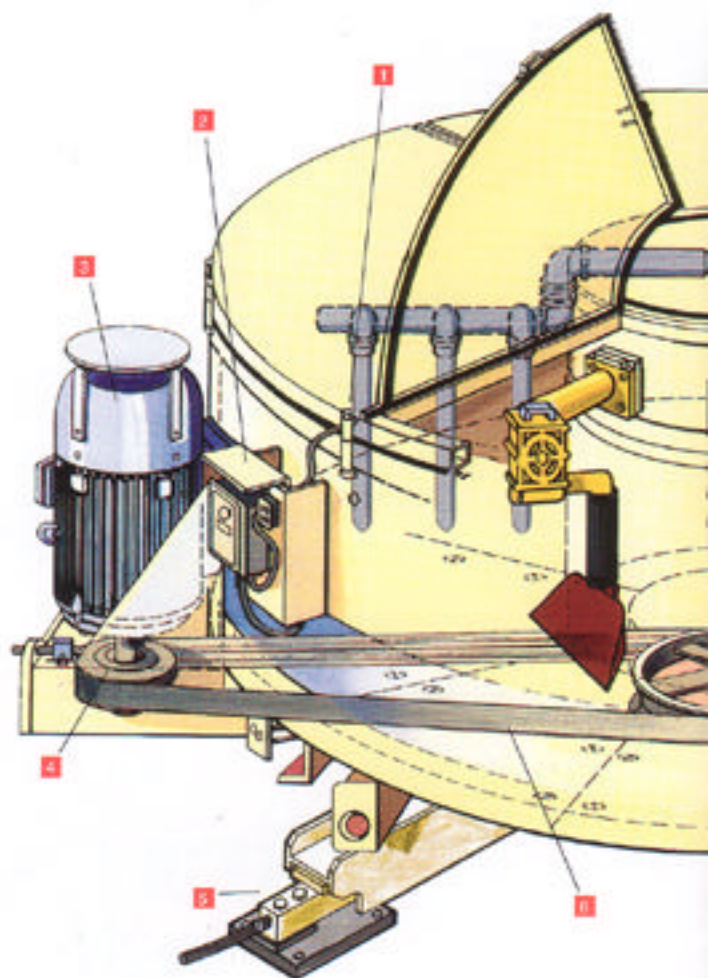

D U S T M A S T E R S e r i e s

1 Electric Interlocks protect personnel. System of safety engineered interlocks and cutouts shut down the Turbin mixer when moving parts are exposed. An audible alarm start system sounds before the mixer starts.

2 Programmable Controller (not shown) features fully automatic operation including easy adjustments to mixing time, water-to-solids ratio and batch weight.

3 Reducer Lubrication System (hidden) is self-lubricating and sealed against contamination.

4 Heavy Duty Motor is totally enclosed for dust protection and fan cooled for long life. Motor and V-belt adjustment is very convenient.

5 Gyro-Drive Reducer has 2/3 of teeth in constant contact with motor's pinion gear versus one or two teeth for conventional reducers. The

tooth interface is strong, efficient and reliable. Reducer offers 500% overload capacity and has an output torque/ input horsepower ratio of almost 95%.

6 Load cells below DustMASTER Series II assure the required quantity of material is processed each cycle. DustMASTER Series I uses a weigh hopper to measure materials.

WE HAVE NOT ENCOUNTERED A DUST

SOLUTIONS FOR PROBLEM MATERIALS

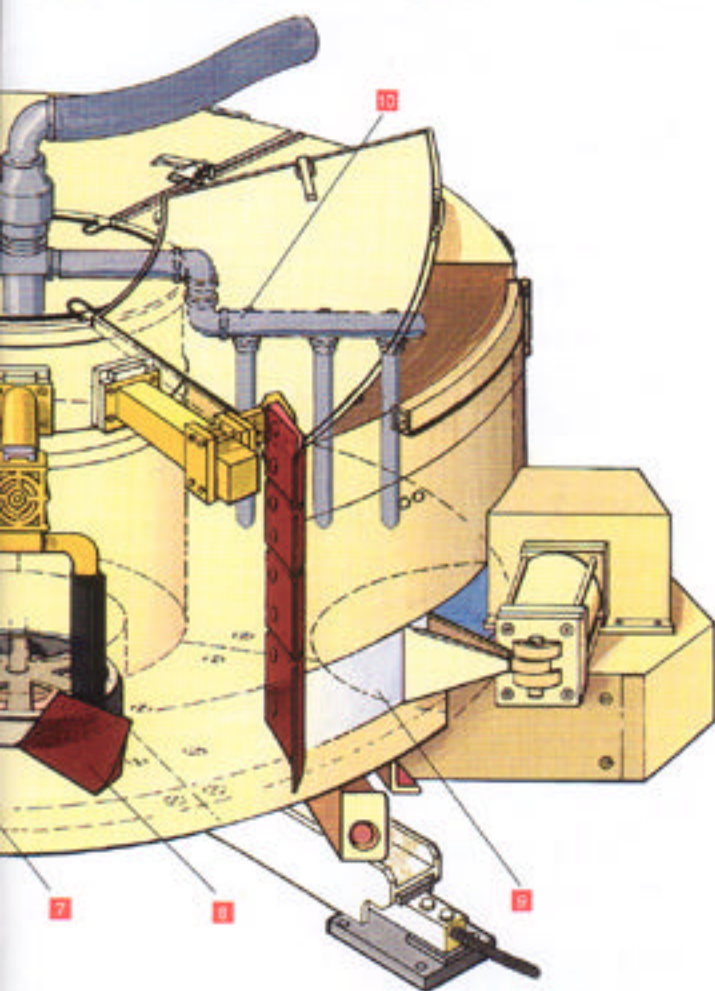

S I L B A T C H S Y S T E M

7 V-Band Belt Drive offers inherent shock protection for the drive train. Proven since 1975, design eliminates maintenance prone and difficult to replace gear boxes, U-joints or chain and sprocket assemblies. Belt tension can be adjusted quickly and easily with bolts on the motor mount.

7 Replaceable Liners with 225 Brinell hardness are standard. For longer life and easier cleanup, rubber or urethane liners are

available. Liner sections are accessible from top of mixer.

10 Paddles are cast Ni-Hard steel, extra abrasion resistant for long life. Hard rubber paddle blades are optional. Paddle height is controlled with one bolt at top of mixing arm. Individual paddles can be quickly replaced by removing two bolts on the back of the mixing arm.

8 Discharge Door (hidden) is hydraulically operated. Door slides in a protected track to

maintain alignment and eliminate binding. Hydraulic power pack is included.

9 Rotary Water Distribution System uses vertical fingers on radial spray bars for fast, controlled liquid introduction into the mixing chamber. Water is gravity injected into mix, so splashing is non-existent or minimal. This contributes to low water usage, shorter cycle times and easier cleanup. Water volume is measured by a flow meter.

Intensive Batch Mixing With Uniform Wetting Produces a Homogenous, Stabilized Mix

At the heart of the DustMASTER system is the high-speed, heavy duty Turbin® Mixer. It produces a homogeneous 100% stabilized mix, batch after batch. Thorough mixing and complete uniform wetting of dusts is achieved with unique concave mixing paddles, and three dimensional mixing action.



Although dependent upon the type of dust, a non-dusting material can be produced in only 30 seconds with as little as eight percent water (or other reagent). With paddles rotating at 600 feet per minute, the mixing action generates excellent dispersion — turns dust into a stabilized uniform, homogenous material.

DustMASTER systems are totally enclosed, meet all the requirements of the accumulation tank process for the treatment of hazardous and non-hazardous material. The DustMASTER system is the fastest, most economical producer of a high quality stabilized product at the lowest operating cost. We guarantee it.

Paddle Mixer Suited For Smaller Stabilization Jobs

For smaller volume stabilization needs, (up to eight tons per hour) the DustMASTER eight cubic foot (0.25 cu. m) horizontal paddle mixer provides proven performance features in a compact design. Cross-current mixing action, longitudinal water dispersion tube and heavy duty, abrasion resistant components contribute to effectiveness of design.

Crane hook and fork lift brackets make for easy transport. Contact factory for more information.



We Have Not Encountered A Dust We Could Not Handle

The DustMASTER batch system is a complete, self-contained unit consisting of a high intensity mixer, volumetric batcher and water system with programmable controls. Eight sizes are available, ranging from 8 to 200 tons per hour. Production is based on dry fly ash weighing 50 lbs./ft³.

Two models in each of the sizes are available: DustMASTER Series I with a weigh batcher; and DustMASTER Series II with load cells under the mixer.

The following is a sample of materials successfully handled by the DustMASTER:

- Baghouse Powder Residue - Steel Mills
- Bottom Ash
- Calcium Oxide - Utilities
- Cement Residue - General Industry
- Cupola Dust - Foundries
- CKD and Alkaline Bypass Dust - Cement Plants

DUSTMASTER A System Guaranteed To Work

This guarantee only applies where all waste powders have been factory tested by DustMASTER Enviro Systems and the prescribed mixing and maintenance instructions of DustMASTER Enviro Systems are followed for the DustMASTER. Any deviations from these instructions will void this guarantee.

Under these conditions, the DustMASTER is guaranteed to thoroughly mix powder and dusty residue materials with water in order to produce a DUST FREE product.

**A FREE TEST OF MATERIALS
TO DETERMINE RESULTS IS
AVAILABLE.**

DM 1.5m 02/01
Printed in U.S.A.
© 2001

- Economizer Ash - Utilities
- Fly Ash - all types, including ash from Powder River Basin and low sulfur coal - Utilities, Steel Mills
- Fly Ash from FBC - General Industry
- Foundry Sand - Foundries
- Hazardous and Non-Hazardous Wastes - General Industry
- Iron Oxides and Heavy Metals - Steel Mills
- Lignite - Utilities
- Incinerated Medical Waste - Medical
- Municipal Incinerator Waste - from MRF Mass Burn and Waste-To-Energy Plants - General Industry
- Nuclear Waste Sludge- Nuclear Power Plants
- Shot Blast - Foundries
- Pyrites - Utilities
- Hot and/or Exothermic Materials
- Sludge and Dry Solids - Wastewater

Call Today

For more information, contact us today and ask about our free DustMASTER video, samples of different test results, and/or user reports on DustMASTER systems in various industries.

DUSTMASTER

Enviro Systems

A Division of Mixer Systems, Inc.

190 Simmons Avenue

P. O. Box 10

Pewaukee, WI 53072

262-691-3100 phone

800-75-MIXER (800-756-4937) toll free phone

262-691-3184 fax

Website: www.dustmaster.com

E-mail: info@dustmaster.com

